

19.06.1020 User manual

For cuts, strips and crimps. With closed lock for stored, use on stranded wire only.

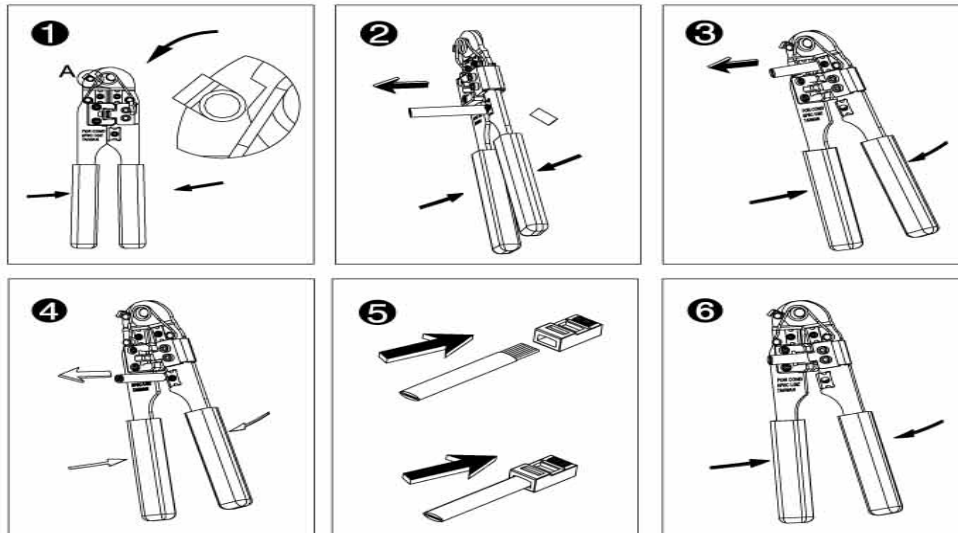

Instructions

1. Squeeze handles and open the lock.
2. Cut the modular cable to the desired length. Make certain that the end are cut squarely, not diagonally.
3. Insert flat cable between stripper blades. Squeeze handles, cable must be keep perpendicular and then pull from the tool.
4. Use HT-210C to strip round cable, insert the cable into the stripping hole and then turn the cable.
5. Remove the outer jacket, insert the stripped cable into the plug, make sure the left wire at one end matches the right wire at the other end.
6. Place modular plug with cable into the tool's holder. Make sure the stripped wire is between the tab and gold contacts. Squeeze handles until it stops.